

Index

General information - Features..... E2
 Technical Data E4
 Ordering code E5
 Dimensions ISO 4 Bolts flange..... E9
 Dimensions SAE C 4 Bolts flange E12
 Dimensions SAE E 4 Bolts flange..... E13

Type	Displacement cm ³ /rev [in ³ /rev]	Max. flow motor l/min [U.S. gpm]	Max. flow pump l/min [U.S. gpm]	Max. pressure cont. bar [psi]
H1C 006	6.067 [0.37]	36.4 [9.61]	30.3 [7.99]	350 [5100]
H1C 040	40.1 [2.45]	175 [46.1]	132 [34.8]	350 [5100]
H1C 226	225.1 [13.73]	540 [142.5]	360 [95]	350 [5100]

H1C series units are a family of fixed displacement pumps and motors, bent axis piston design for operation in both open and closed circuit. The proven design incorporating the lens shape valve plate, the high quality components and manufacturing techniques make the H1C series units to able provide up to 350 bar [5100 psi] continuous and 450 bar [6500 psi] peak performance. Fully laboratory tested and field proven, these units provide maximum efficiency and longlife. Heavy duty bearings permit high radial and axial loads. Versatile design includes a variety of port plate, shaft end and valves package that will adapt the H1C series units to any application both industrial and mobile. H1C series units are available in both ISO and SAE version.



Simbology:

C	N/bar [lbf/psi]	Load
F_{ax max}	N [lbf]	Axial pushing load
F_{ax max}	N [lbf]	Axial pulling load
F_q	N [lbf]	Radial load
F_{q max}	N [lbf]	Maximum permissible radial load
J	kg·m ² [lbf·ft ²]	Moment of inertia
m	kg [lbs]	Weight
n_{max}	rpm	Maximum speed
p_{max}	bar [psi]	Maximum continuous pressure
p_{peak}	bar [psi]	Maximum pressure peak

Q_{max}	l/min [U.S. gpm]	Maximum flow
Q_d	l/min [U.S. gpm]	External drain flow
T_k	Nm/bar [lbf.ft/psi]	Torque constant
T_{max}	Nm [lbf.ft]	Maximum torque at pressure continuous
T_{peak}	Nm [lbf.ft]	Maximum torque at pressure peak
V_g	cm ³ /rev [in ³ /rev]	Displacement
P_{max}	kW [hp]	Maximum power at p _{nom}
η_{hm}	%	Mech-hyd. efficiency
η_v	%	Volumetric efficiency

Hydraulic fluids:

Use fluids with mineral oil basis and anticorrosive, antioxidant and wear preventing addition agents (HL or HM). Viscosity range at operating temperature must be of 15 ÷ 40 cSt. For short periods and upon cold start, a max. viscosity of 800 cSt is allowed. Viscosities less than 10 cSt are not allowed. A viscosity range of 10 ÷ 15 cSt is allowed for extreme operating conditions and for short periods only. For further information see on the General Information Catalogue, the section "Fluids and filtering".

Temperature ranges:

The operating temperature of the oil must be within -25°C ÷ 90°C [-13°F ÷ 194°F]. The running of the axial piston unit with oil temperature higher than 90°C [194°F] or lower than -25°C [-13°F] is not allowed. For further information see at Fluids and filtering section.

Filtering:

A correct filtering is essential for long and satisfactory life of axial piston units. In order to ensure a correct functioning of the unit, the max. permissible contamination class is 21/19/16 according to ISO 4406:1999. For further details see on the General Information Catalogue, the section "Fluids and filtering".

Inlet pressure:

(Pumps in open circuit) Minimum absolute pressure at suction port is 0.8 bar [11.6 psi]. In no circumstances can inlet pressure be lower.

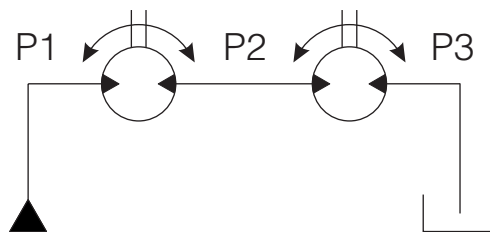

Operating pressure:

The maximum permissible pressure on pressure ports is 350 bar [5100 psi] continuous and 450 bar [6500 psi] peak. If two motors are connected in series, working pressure has to be limited to following values: P1 400 bar max. [5800 psi] and P2 200 bar max. [2900 psi].

Case drain pressure:

Maximum permissible case drain pressure is 1.5 bar [22 psi]. A higher pressure can affect the main shaft seal or reduce its life.

Seals:

Seals used on standard H1C series axial piston pumps/motors are of NBR (Acrylonitrile-Butadiene Elastomer). For special uses (high temperatures or corrosive fluids) it is possible to order the unit with FKM seals (Fluoroelastomer). In case of use of special fluids, contact Dana.

Output shaft:

Main shaft has bearings that can bear both radial and axial loads. As for loads permissible values, see on the General Information Catalogue, the section "Service life of bearings for axial piston units".

Minimum rotating speed:

Minimum rotating speed is the minimum speed ensuring a smooth running of the piston unit. Operation smooth at low speeds depends on many factors, as type of load and operating pressure. At a speed higher than 150 rpm, a smooth running is ensured almost in every case. Lower speeds are, usually, possible. Please contact Dana.

Installation:

H1C series pumps and motors can be installed in every position or direction. These axial piston units have separate ports and drain chambers and so must be always drained. As for pumps, installation of the unit with shaft in vertical position and above the tank involves some limitations. For further details see on the General Information Catalogue, the section "General installation guidelines".

Flangeable valves:

Flangeable valves are available for motors both in open and closed loop. For further details see at Valves Catalogue.

Relation between direction of rotation and direction of flow:

The relation between direction of rotation of shaft and direction of flow in H1C piston units is shown in the picture below.

Note: for pump operation, the direction of rotation is determined by the port plate mounting position. Usually, in order to change direction of rotation of a pump, port plate has to be removed, turned of 180° and reassembled.

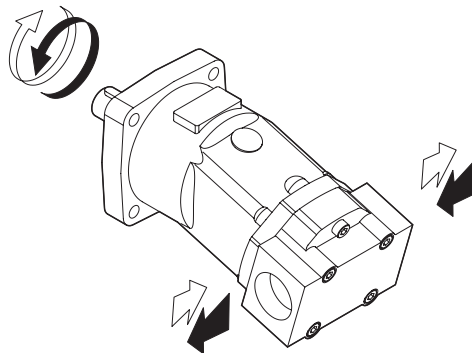

Reversible motor

			Size		
			006	040	226
Displacement	V_g	cm ³ /rev [in ³ /rev]	6.067 [0.37]	40.1 [2.45]	225.1 [13.73]
Max. pressure	P_{max}	bar [psi]	350 [5100]	350 [5100]	350 [5100]
Max. peak pressure	P_{peak}	bar [psi]	450 [6500]	450 [6500]	450 [6500]
Max. speed motor	n_{max}	rpm	6500	4350	2400
Max. flow motor	Q_{max}	l/min [U.S.gpm]	36.4 [9.61]	175 [46.1]	540 [142.5]
Max. power at p_{max} motor	P_{max}	kW [hp]	21.2 [28.4]	102 [136.8]	315 [422]
Torque constant	T_k	Nm/bar [lbf.ft/psi]	0.097 [0.005]	0.64 [0.032]	3.58 [0.182]
Max. torque at p_{max}	T_{max}	Nm [lbf.ft]	33.8 [24.9]	223 [164]	1254 [925]
Max. torque at p_{peak}	T_{peak}	Nm [lbf.ft]	43.5 [32.1]	288 [212]	1613 [1189]
Moment of inertia ⁽³⁾	J	kg·m ² [lbf.ft ²]	0.0007 [0.016]	0.004 [0.094]	0.040 [0.949]
Weight ⁽³⁾	m	kg [lbs]	5.5 [12.1]	22 [48.5]	86 [189.5]
External drain flow ⁽⁴⁾	Q_d	l/min [U.S.gpm]	0.4 [0.10]	0.7 [0.18]	2.5 [0.66]

(Theoretical values, without considering η_{hm} e η_v approximate values). Peak operations must not exceed 1% of every minute. A simultaneous maximum pressure and maximum speed not recommended.

Notes: Calculation of permissible speed

(1) The pump rotation speed may be increased by increasing the suction pressure. The max. pump speed must be always less than value n_0 max shown in table. To calculate the max. permissible speed related to the pump suction pressure see the diagram at side. (2) The values are valid for a rotating speed of n_1 max. (3) Approximate values. (4) Average values at 250 bar [3600 psi] with mineral oil at 45°C [113°F] and 35 cSt of viscosity.

Speed limits calculation

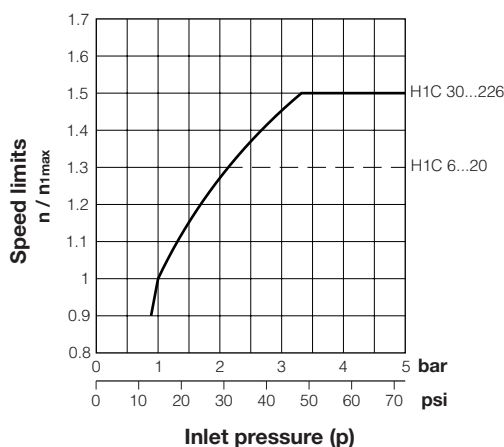

The following alphanumeric codes system has been developed to identify all of the configuration options for the H1C series. Use the model code below to specify the desired features.

All alphanumeric digits system of the code must be present when ordering.

We advise to carefully read the catalogue before filling the ordering code.

1	2	3	4	5	6	7	8	9	10	11	12	13	14
Series	Motor/pump	Size	Version	Mount flange	Shaft end	Port cover	Direction of rotation	Seal	Valve	Valves feature	Flushing valve	Special feature	Painting
H1C	M	006	ME/SE	OA	CAV	LM1	RV	N/V	XXXX	000	XX	XX	XX

1	Series
H1C	Fixed displacement, bent axis, axial piston unit

2	Motor / Pump
M	Motor

3	Size
006	6.067 cm ³ /giro [0.37 in ³ /rev]
040	40.1 cm ³ /giro [2.45 in ³ /rev]
226	225.1 cm ³ /giro [13.73 in ³ /rev]

4	Version
ME	ISO
SE	SAE

5	Mount flange	Size		
		006	040	226
OA	ISO 4 Bolts Ø 80 mm [Ø 3.12 in]	ME	-	-
OC	ISO 4 Bolts Ø 125 mm [Ø 4.92 in]	-	ME	-
05	SAE-C 4 Bolts	-	SE	-
OG	ISO 4 Bolts Ø 200 mm [Ø 7.88 in]	-	-	ME
10	SAE-E 4 Bolts	-	-	SE

--: Not Available

1) The ME digit means that the flange is only available for the ISO version

2) The SE digit means that the flange is only available for the SAE version



1	2	3	4	5	6	7	8	9	10	11	12	13	14
H1C	M	006	ME/SE	OA	CAV	LM1	RV	N/V	XXXX	000	XX	XX	XX

6

Shaft end		Size		
		006	040	226
CAV	Parallel keyed Ø 20 mm k6 [0.79 in k6]	ME	-	-
SAF	Splined W20x1.25x14x9g DIN 5480	ME	-	-
CAW	Parallel keyed Ø 30 mm k6 [1.18 in k6]	-	ME ⁽¹⁾	-
SAI	Splined W30x2x14x9g DIN 5480	-	ME ⁽¹⁾	-
C17	Parallel keyed Ø 31.75 mm [1.25 in]	-	SE ⁽²⁾	-
S12	Splined 14T 12/24 DP	-	SE ⁽²⁾	-
C18	Parallel keyed Ø 44.45 mm [1.75 in]	-	-	SE ⁽²⁾
S15	Splined 13T 8/16 DP	-	-	SE ⁽²⁾
CAX	Parallel keyed Ø 50 mm k6 [1.97 in k6]	-	-	ME ⁽¹⁾
SAR	Splined W50x2x24x9g DIN 5480	-	-	ME ⁽¹⁾

- : Not available

1) The ME digit means that the shaft is only available for the ISO version

2) The SE digit means that the shaft is only available for the SAE version

7

Port Cover		Size		
		006	040	226
FM1	Frontal ports	ME ⁽⁴⁾	ME ⁽¹⁾	-
LM2	Lateral ports	-	ME-SE	ME-SE
VM2 ⁽³⁾	Lateral ports same side	-	ME-SE	-
FLM	Special FM1+LM1	ME ⁽⁴⁾	-	-

- : Not Available

(*) The port cover threads are ISO also in SAE option.

1) The ME digit means that the port cover is only available for the ISO version.

2) The SE digit means that the port cover is only available for the SAE version.

3) The ME-SE digit means that the port cover is available for the ISO and SAE version.

4) Special on request.

8

Direction of rotation (viewed from shaft side)	
RV	Reversible

1	2	3	4	5	6	7	8	9	10	11	12	13	14
H1C	M	006	ME/SE	OA	CAV	LM1	RV	N/V	XXXX	000	XX	XX	XX

9	
Seal	
N	NBR
V	FKM

10		Valve		
		Size		
		006	040	226
XXXX	None	●	●	●
VCDM	VCD/M Pilot assisted overcentre valve	-	VM2	-
VCD1	VCD/1 Pilot assisted overcentre valve	-	LM2	LM2
VCD2	VCD/2 Pilot assisted overcentre valve	-	-	LM2
VCR3	VCR3 Double acting overcentre valve	-	VM2	-
VSD1	VSD 120 anti-shock valve	-	-	LM2

●: Available
 -: Not Available

The valves are available with ISO port cover only, please contact Technical department for SAE version The VSD1 is not available with flushing valve.

- 1) The VM2 digit means that the valve is only available with VM2 port cover.
- 2) The LM2 digit means that the valve is only available with LM2 port cover.

11		Valves					
Valves feature		XXXX	VCDM	VCD1	VCD2	VCR3	VSD1
000	Feature not necessary	●	-	-	-	-	-
004	Not Set 30÷350 bar [435 to 5075 psi] [Piloting ratio 6.2:1] Control of rotation CW	-	●	-	-	-	-
005	Not Set 30÷350 bar [435 to 5075 psi] [Piloting ratio 6.2:1] Control of rotation CCW	-	●	-	-	-	-
002	Not Set 0÷350 bar [0 to 5075 psi] [Piloting ratio 2.9:1] Control of rotation CW	-	-	●	-	-	-
006	Not Set 0÷350 bar [0 to 5075 psi] [Piloting ratio 2.9:1] Control of rotation CCW	-	-	●	-	-	-
003	Not Set 250÷500 bar [3625 to 7250 psi] [Piloting ratio 13:1] Control of rotation CW	-	-	-	●	-	-
007	Not Set 250÷500 bar [3625 to 7250 psi] [Piloting ratio 13:1] Control of rotation CCW	-	-	-	●	-	-
014	Not Set (Max setting 350 bar [5075 psi]) Control of rotation CW	-	-	-	-	-	●
015	Not Set (Max setting 350 bar [5075 psi]) Control of rotation CCW	-	-	-	-	-	●
012	Not Set [Piloting ratio 8:1]	-	-	-	-	●	-

●: Available
 -: Not Available

Please contact Technical department for valve which require specific setting.
 For the feature see catalogue valves.



1	2	3	4	5	6	7	8	9	10	11	12	13	14
H1C	M	006	ME/SE	OA	CAV	LM1	RV	N/V	XXXX	000	XX	XX	XX

12

Lushing valve		Size		
		006	040	226
XX	Not Required	●	●	●
06	Flushing Valve VSC/F - 6 l/min	-	LM2-VM2	LM2
09	Flushing Valve VSC/F - 10.5 l/min	-	LM2-VM2	LM2
15	Flushing Valve VSC/F - 15 l/min	-	LM2-VM2	LM2

- : Available
- : Not Available

It is not possible to combine the flushing valves with valve in pos.10
For the feature see catalogue valves.

13

Special feature		Size		
		006	040	226
XX	None	●	● ¹⁾	●
01	Special shaft seal 5 bar [72.5 psi]	-	● ²⁾	●
03	SAE Version with ISO port cover	-	● ³⁾	● ⁴⁾

- : Available
- : Not Available

1) Not available with SAE version and VM2 port cover.
2) Only with NBR seals.
3) Available with FM1 - VM2 - LP2 port cover.
4) Available with LM2 port cover.

14

Painting	
XX	None
01	Black Painted RAL 9005
02	Blue Painted RAL 5015

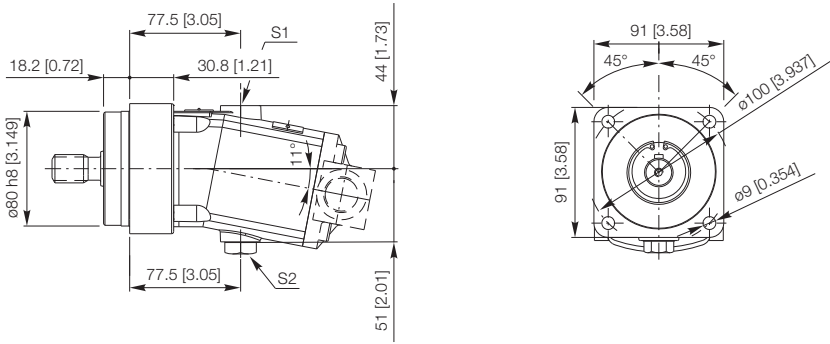

S1, S2: Drain ports (1 plugged) - 3/8 G (BSPP)
 A, B: Service line ports
 S: Suction port

7

Port cover

LM1

FLM

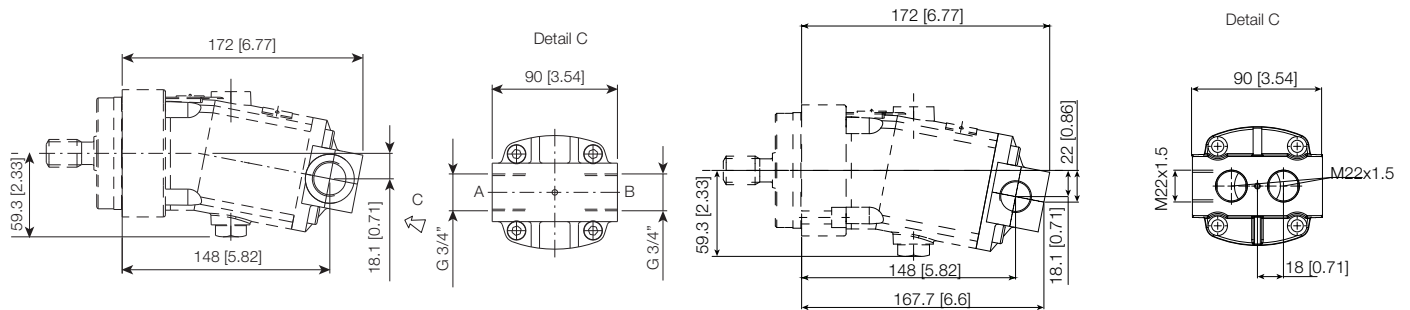

FM1

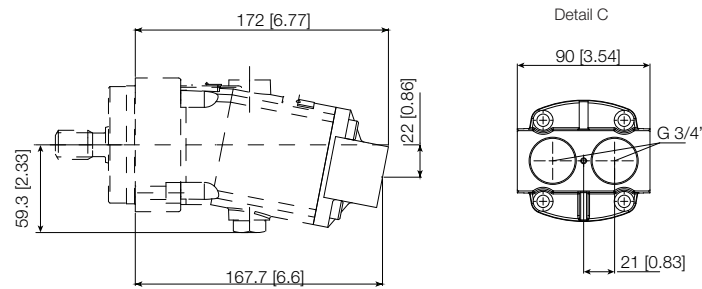

6

Shaft end

CAV

Splined shaft

SAF

Splined shaft

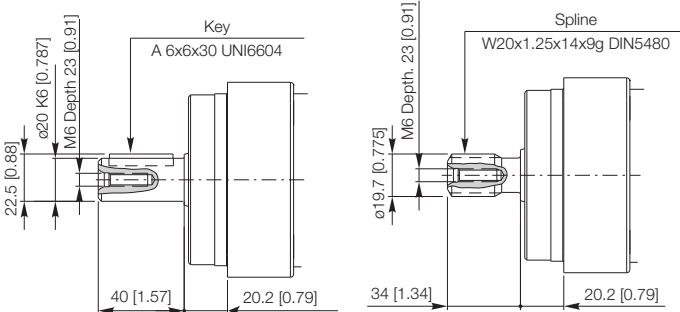

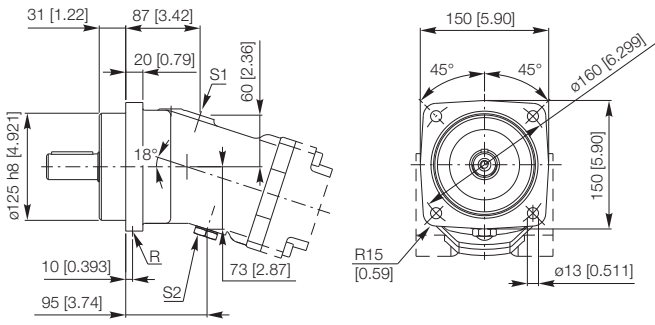

S1, S2: Drain ports - (1 plugged) - 1/2 G (BSPP)
 A, B: Service line ports
 S: Suction port
 R: Air bleed (plugged) - 1/8 G (BSPP)

7 Port cover

FM1

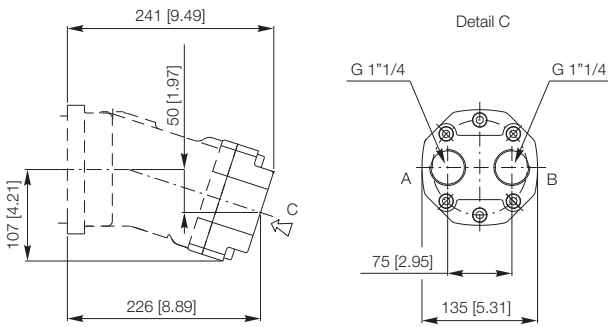

LM2

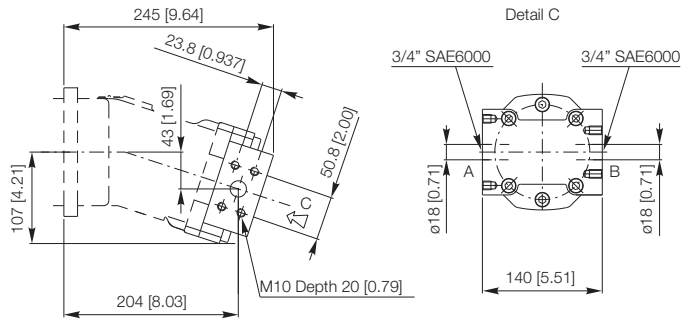

VM2

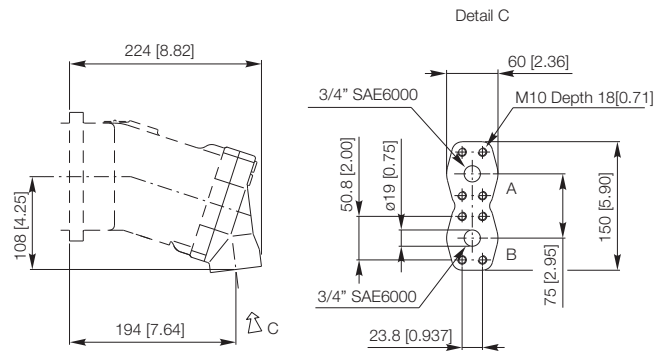

6 Shaft end

CAW Parallel keyed shaft

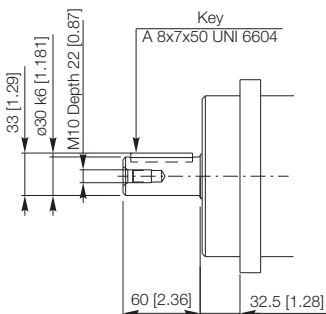

SAI Splined shaft

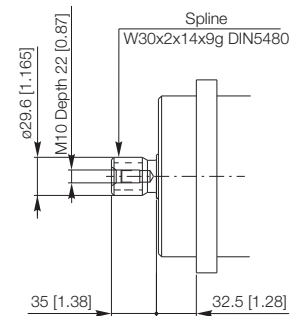

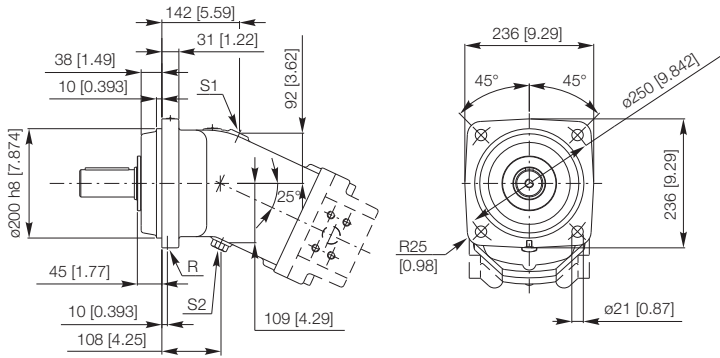

S1, S2: Drain ports (1 plugged) - 3/4 G (BSPP)
 A, B: Service line ports
 S: Suction port
 R: Air bleed (plugged) - 1/8 G (BSPP)

7

Port cover

LM2

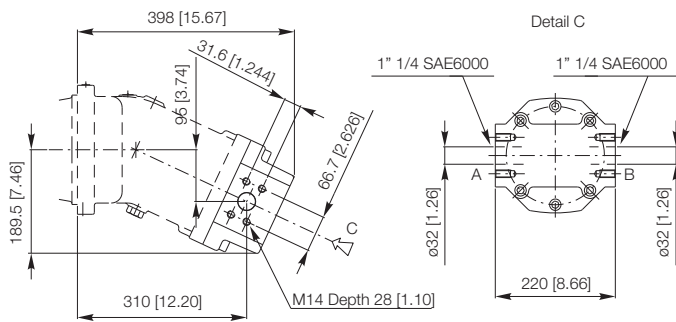

6

Shaft end

CAX Parallel keyed shaft

SAR Splined shaft

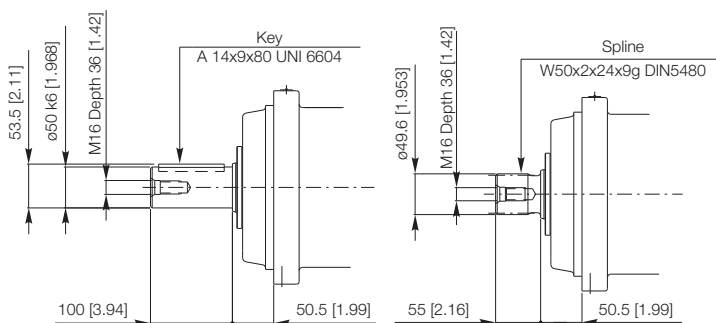

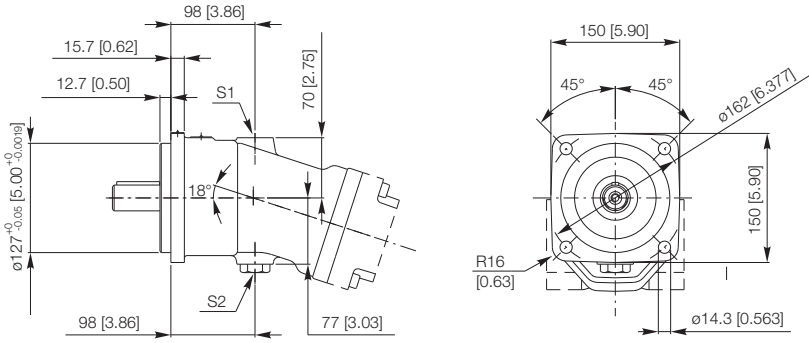

S1, S2: Drain ports (1 plugged) - 1" 1/16-12 UN 2BA, A, B: Service line ports
S: Suction port

7

Port cover

LM2

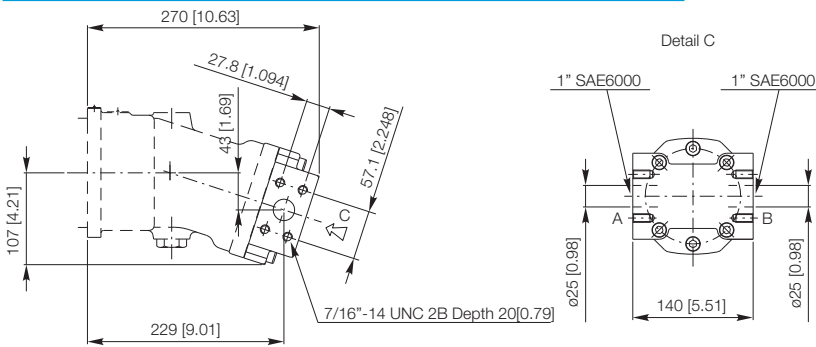

VM2

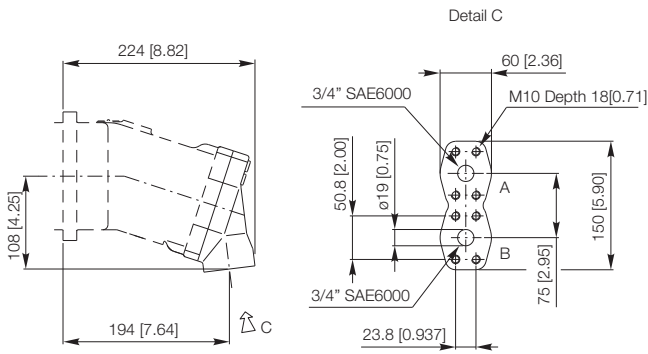

6

Shaft end

C17

Splined shaft

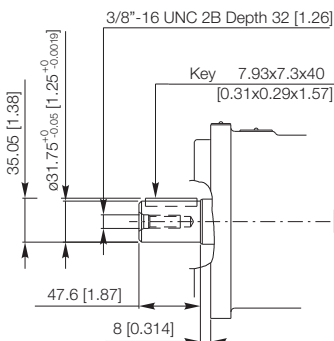

S12

Splined shaft

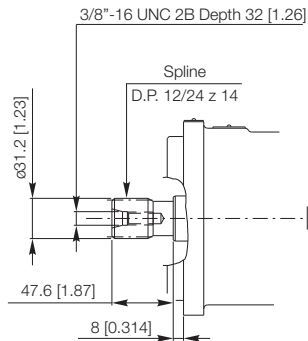

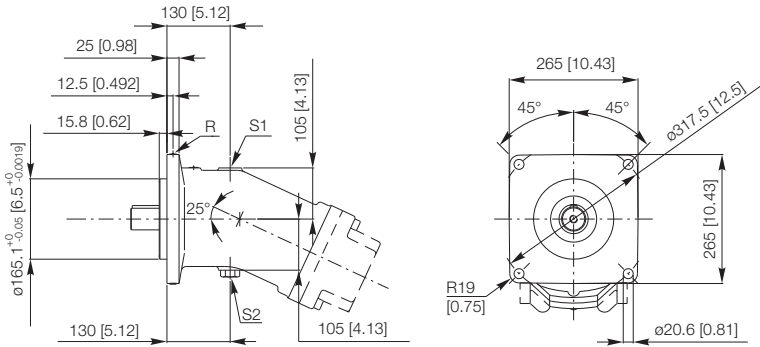

S1, S2: Drain ports (1 plugged) - 1" 3/16-12 UN 2B
 A, B: Service line ports
 S: Suction port
 R: Air bleed (plugged) - 7/16"-20 UNF

7 Port cover

LM2

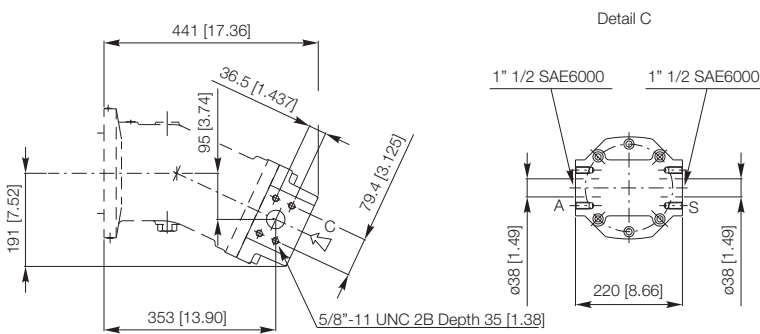

6 Shaft end

C18 Parallel keyed shaft

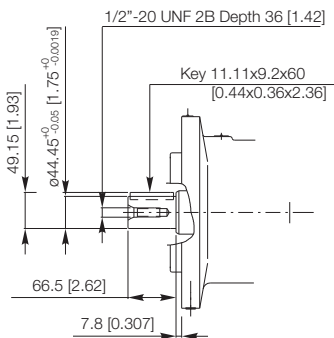

S15 Splined shaft

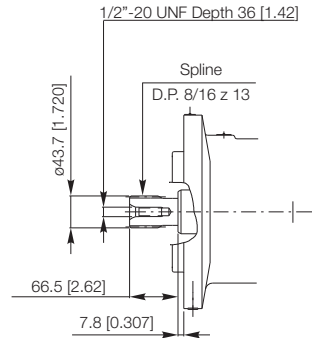



BREVINI[®]

Motion Systems

