

Process transmitter

Model UPT-20, with pressure port

Model UPT-21, with flush diaphragm

WIKA data sheet PE 86.05



for further approvals
see page 16



Applications

- Control and process technology
- Machine building and plant construction
- Pharmaceutical and hygienic industries
- Food industry
- Chemical, petrochemical industry

Special features

- Multi-functional display
- Simple menu navigation
- Conductive plastic case or stainless steel case (optionally with electropolished surface)
- Large LC display, rotatable
- Approvals for hazardous areas



Fig. left: Plastic case
Fig. right: Stainless steel case with electropolished surface

Description

Instrument construction

The model UPT-2x process transmitter has been developed for applications which require an intelligent sensor. Particularly the integrated temperature compensation makes the process transmitter interesting for a wide range of applications.

The measuring cell is made of stainless steel 316L or of a combination with high-quality Elgiloy®. For specific requirements, further special materials are available.

The case is rotatable by 330° and the LC display can be mounted in different positions, displaceable in 90° steps. The LC display is easy to read in any mounting position, even from a distance of up to 5 m.

Elgiloy® is a trademark of the company "Specialty Metals"

HART® protocol

The process transmitter can be installed both in applications using analogue technique and modern systems communicating via the HART® protocol.

Via the display and operating module or the HART interface this process transmitter can be configured directly on site or remotely via a process control system.

Turndown

An adjustable turndown allows to register exact process values with optimised limits of the measuring values and without major restrictions of the accuracy.

Measuring ranges

Gauge pressure						
bar	0 ... 0.4	0 ... 1.6	0 ... 6	0 ... 16	0 ... 40	0 ... 100
	0 ... 250	0 ... 600	0 ... 1,000	0 ... 1,600	0 ... 2,500	0 ... 4,000
psi	0 ... 10	0 ... 15	0 ... 30	0 ... 100	0 ... 300	0 ... 500
	0 ... 1,500	0 ... 5,000	0 ... 10,000	0 ... 15,000	0 ... 30,000	0 ... 50,000
	0 ... 60,000					

Absolute pressure						
bar	0 ... 1.6	0 ... 6	0 ... 16	0 ... 40		
psi	0 ... 30	0 ... 100	0 ... 300	0 ... 500		

Vacuum and +/- measuring ranges						
bar	-1 ... 0	-0.2 ... +0.2	-1 ... +0.6	-1 ... +5	-1 ... +15	-1 ... +40
psi	-14.5 ... 0	-14.5 ... +15	-14.5 ... +100	-14.5 ... +300	-14.5 ... +600	

Other measuring ranges can be set via turndown.

For measuring ranges above 600 bar [10,000 psi] only the model UPT-20 is available.

Vacuum tightness

Vacuum resistance is provided, except for instruments for oxygen applications.

Overload safety

Measuring ranges ≤ 40 bar [500 psi]:	3 times
Measuring ranges 40 ... 1,000 bar [500 ... 15,000 psi]:	2 times
Measuring ranges 1,000 ... 1,600 bar [15,000 ... 30,000 psi]:	1.5 times
Measuring ranges > 1,600 bar [30,000 psi]:	1.3 times

Output signals

Output signals	
Standard	4 ... 20 mA
Option	4 ... 20 mA with HART® signal

Load in Ω

≤ U₊ - 12 V / 0,023 A (non-Ex)

≤ U₊ - 14 V / 0,023 A (Ex)

U₊ = Applied power supply (see "Power supply")

Damping

0 ... 99.9 s, adjustable

After the set damping time the instrument outputs 63 % of the applied pressure as output signal.

Settling time t₉₀

60 ms without HART®

80 ms with HART®

Refresh rate

20 ms without HART®

50 ms with HART®

Voltage supply (non-Ex)

Power supply U₊

DC 12 ... 36 V

Voltage supply (Ex)

Power supply U₊: DC 14 ... 30 V
Maximum voltage U_i: DC 30 V
Maximum current I_i: 100 mA
Maximum power P_i (gas): 1,000 mW
Maximum power P_i (dust): 750/650/550 mW (depending on the max. ambient temperature)
Effective internal capacitance: 11 nF
Effective internal inductance: 100 μH

For more information, see "Approvals"

Reference conditions (per IEC 61298-1)

Temperature

23 °C ± 2 °C [73 °F ± 7 °F]

Power supply

DC 23...25 V

Atmospheric pressure

860 ... 1,060 mbar [86 ... 106 kPa, 12.5 ... 15.4 psi]

Air humidity

45 ... 75 % r. h.

Characteristic curve determination

Terminal method per IEC 61298-2

Curve characteristics

Linear

Reference mounting position

Vertical, diaphragm points downward

Accuracy specifications

Accuracy at reference conditions

Including non-linearity, hysteresis, zero offset and end value deviation (corresponds to measured error per IEC 61298-2).

Accuracies	
Standard	0.15 % of span
Option 1	0.10 % of span
Option 2	0.20 % of span
Option 3	0.50 % of span (> 1.000 bar [15,000 psi])

Mounting correction

-20 ... +20 %

Non-repeatability

Measuring ranges $\leq 1,000$ bar [15,000 psi]: ≤ 0.1 % of span

Measuring ranges $> 1,000$ bar [15,000 psi]: ≤ 0.5 % of span

Behaviour with turndown

For measuring ranges from 0 ... 1.6 bar to 0 ... 1,000 bar [0 ... 25 psi to 0 ... 15,000 psi]

- TD $\leq 5:1$ No influence on the accuracy
- TD $> 5:1 \dots \leq 100:1$ GES = GG x TD / 5

For measuring range < 1.6 bar [30 psi]

- TD = 1:1 No influence on the accuracy
- TD $> 1:1 \dots \leq 100:1$ GES = GG x (TD + 4) / 5

For measuring range $> 1,000$ bar [15,000 psi]: ≤ 0.5 x TD

Legend

GES: Overall accuracy via turndown

GG: Accuracy (e.g. 0.15 %)

TD: Turndown factor (e.g. 4:1 corresponds to TD factor 4)

Long-term stability

Measuring range < 1 bar [14.5 psi]: 0.35 %/year

Measuring range ≥ 1 bar [14.5 psi]: 0.15 %/year

Measuring range ≥ 1.6 bar [30 psi]: 0.10 %/year

Measuring range ≥ 40 bar [600 psi]: 0.10 %/year

Measuring range $> 1,000$ bar [15,000 psi]: ≤ 0.5 %/year

Thermal change, zero point / span (reference temperature 20 °C [68 °F])

In the temperature-compensated range 10 ... 70 °C [50 ... 158 °F] : No additional temperature error (only valid up to 1,000 bar [15,000 psi])

Outside compensated range: Typical < 0.1 %/10 K (at $> 1,000$ bar [15,000 psi]: 0.2 %/10 K)

Thermal change of the current output (reference temperature 20 °C [68 °F])

< 18 °C and > 28 °C [< 64 °F and > 82 °F]: 0.1 %/10 K (max. 0.15 %/10 K)

Operating conditions

Range of applications

The process pressure transmitter is suitable for internal and external operation. Direct exposure to sunlight is permitted.

Permissible air humidity

≤ 93 % r. h.

Permissible temperature ranges

Ambient temperature	
Instrument with display and operating unit	-20 ... +60 °C [-4 ... +140 °F]
Instrument without display and operating unit	-40 ... +80 °C [-40 ... +176 °F] ¹⁾

1) Instrument with angular connector or circular connector: -30 ... +80 °C [-22 ... +176 °F]

Storage temperature	
-40 ... +80 °C [-40 ... +176 °F]	

Medium temperature	
Oxygen application	-20 ... +60 °C [-4 ... +140 °F]
Model UPT-20	-40 ... +85 °C [-40 ... +185 °F]
	-40 ... +105 °C [-40 ... +221 °F] at max. 40 °C [104 °F] ambient temperature
	-40 ... +120 °C [-40 ... +248 °F] at max. 30 °C [86 °F] ambient temperature
UPT-21 without cooling element	85 °C [185 °F] at max. 80 °C [176 °F] ambient temperature
	105 °C [221 °F] at max. 40 °C [104 °F] ambient temperature
	120 °C [248 °F] at max. 30 °C [86 °F] ambient temperature
UPT-21 with cooling element	85 °C [185 °F] at max. 80 °C [176 °F] ambient temperature
	120 °C [248 °F] at max. 50 °C [122 °F] ambient temperature
	150 °C [302 °F] at max. 40 °C [104 °F] ambient temperature

Additional specifications for temperature ranges for Ex protection

For Ex instruments, the following temperature ranges apply, in addition to the temperature ranges for non-Ex instruments.

Temperature class / surface temperatures for all variants **without** cooling element:

Temperature class / surface temperature	Ambient and medium temperature
T5, T6	$-40 \leq T_a \leq +60 \text{ °C}$ [$-40 \leq T_a \leq +140 \text{ °F}$]
T4	$-40 \leq T_a \leq +80 \text{ °C}$ [$-40 \leq T_a \leq +176 \text{ °F}$]
T135 °C [T257 °F]	$-40 \leq T_a \leq +40 \text{ °C}$ [$-40 \leq T_a \leq +104 \text{ °F}$] for $P_i = 750 \text{ mW}$ $-40 \leq T_a \leq +70 \text{ °C}$ [$-40 \leq T_a \leq +158 \text{ °F}$] for $P_i = 650 \text{ mW}$ $-40 \leq T_a \leq +80 \text{ °C}$ [$-40 \leq T_a \leq +176 \text{ °F}$] for $P_i = 550 \text{ mW}$

Temperature class / surface temperatures for all variants **with** cooling element:

Temperature class	Max. medium temperature	Ambient temperature
T4	120 °C [248 °F]	$-40 \leq T_a \leq +50 \text{ °C}$ [$-40 \leq T_a \leq +122 \text{ °F}$]
T3	150 °C [302 °F]	$-40 \leq T_a \leq +40 \text{ °C}$ [$-40 \leq T_a \leq +104 \text{ °F}$]

Restrictions to medium temperature due to sealing (only for model UPT-21)

	Material	Max. medium temperature
Standard	NBR	-20 ... +105 °C [-4 ... +221 °F]
Option 1	FKM	-20 ... +105 °C [-4 ... +221 °F]
Option 2	FKM	-20 ... +150 °C [-4 ... +302 °F] ¹⁾
Option 3	EPDM	-40 ... +105 °C [-40 ... +221 °F]
Option 4	EPDM	-40 ... +150 °C [-40 ... +302 °F] ¹⁾

1) Process connection with cooling element

Vibration resistance

4 g (5 ... 100 Hz) per GL characteristic curve 2

Shock resistance

Measuring range ≤ 1,000 bar [15,000 psi]: 150 g (3.2 ms) per IEC 60068-2-27

Measuring range > 1,000 bar [15,000 psi]: 20 g at 4.6 ms

Ingress protection

IP66/67

IP65 for versions with circular connector, angular connector or overvoltage protection

Ingress protection only applies with closed case head and closed cable glands.

Explosion protection

see approvals

Display and operating unit, model DI-PT-U (option)

Display type

LC display, for the process transmitter only this display may be used. For order number see accessories.

Refresh rate

200 ms

Main display

4 ½-digit

Segment display

Character size 14 mm

Additional display

Selectable via menu, three-line scale range

Bar graph display

20 segments, radial, pressure gauge simulation

Colours

Background: Light grey, Digits: Black

Operating state

Display via symbols

Ambient temperatures

When using the display and operating unit, the temperature for operation is limited to -20 ... +60°C [-4 ... +140 °F].

Storage temperatures

When using the display and operating unit, the temperature for storage is limited to -40 ... +80°C [-40 ... +176 °F].

Process connections

With pressure port (for model UPT-20)

Per standard	Thread size	Possible measuring ranges
EN 837	G 3/8 B	≤ 0 ... 1,000 bar [0 ... 15,000 psi]
	G 1/2 B	≤ 0 ... 1,000 bar [0 ... 15,000 psi]
	M20 x 1.5	≤ 0 ... 1,000 bar [0 ... 15,000 psi]
ANSI / ASME B1.20.1	1/2 NPT	≤ 0 ... 1,000 bar [0 ... 15,000 psi]
	1/2 NPT, female	≤ 0 ... 1,000 bar [0 ... 15,000 psi]
	1/4 NPT	≤ 0 ... 1,000 bar [0 ... 15,000 psi]
-	M16 x 1.5 mm female with sealing cone	≥ 0 ... 100 bar [0 ... 1,500 psi]
	M20 x 1.5 mm female with sealing cone	≥ 0 ... 100 bar [0 ... 1,500 psi]
	9/16-18 UNF female F 250-C	≥ 0 ... 100 bar [0 ... 1,500 psi]
	1 1/8 -12 UNF female F 562-C	≥ 0 ... 100 bar [0 ... 1,500 psi]

With flush diaphragm (for model UPT-21)

Per standard	Thread size	Possible measuring ranges
-	G 1/2 B	0 ... 6 to 0 ... 600 bar [0 ... 100 to 0 ... 5,000 psi]
	G 1 B	≤ 0 ... 1.6 bar [0 ... 30 psi]
	G 1 1/2 B	≤ 0 ... 1.6 bar [0 ... 30 psi]
	G 1 hygienic ¹⁾²⁾	≤ 0 ... 16 bar [0 ... 100 psi]
	G 1 hygienic mit Kühlstrecke ²⁾	≤ 0 ... 16 bar [0 ... 100 psi]
	M44 x 1.25 with union nut	≤ 0 ... 40 bar [0 ... 500 psi]
Tri-clamp	DN 1 1/2 with cooling element for 150 °C [302 °F]	≤ 0 ... 40 bar [0 ... 500 psi] ⁴⁾
	DN 2 with cooling element for 150 °C [302 °F]	≤ 0 ... 40 bar [0 ... 500 psi] ⁴⁾
Clamp DIN 32676	DN 40 with cooling element for 150 °C [302 °F]	≤ 0 ... 40 bar [0 ... 500 psi] ⁴⁾
	DN 50 with cooling element for 150 °C [302 °F]	≤ 0 ... 40 bar [0 ... 500 psi] ⁴⁾
Grooved union nut DIN 11851 with conical coupling ³⁾	DN 25 with cooling element for 150 °C [302 °F]	≤ 0 ... 40 bar [0 ... 500 psi]
	DN 50 with cooling element for 150 °C [302 °F]	≤ 0 ... 25 bar [0 ... 500 psi]
NEUMO BioConnect [®]	DN 40 form V with cooling element for 150 °C [302 °F]	≤ 0 ... 16 bar [0 ... 500 psi]
VARIVENT [®]	Form N with cooling element for 150 °C [302 °F] DN 40 ... 50	≤ 0 ... 16 bar [0 ... 500 psi]
	Form F with cooling element for 150 °C [302 °F] DN 25	≤ 0 ... 16 bar [0 ... 500 psi]

BioConnect[®] is a registered trademark of the company NEUMO.
VARIVENT[®] is a registered trademark of GEA Tuchenhagen GmbH.

1) Also available as a high-temperature version up to 150 °C [302 °F].

2) Suitable for WIKA adapter system model 910.61, see data sheet AC 09.20

3) For a 3-A conform connection, for process connections with milk thread fittings per DIN 11851, profile sealings from SKS Komponenten BV or Kieselmann GmbH must be used.

4) For the maximum pressure, the permissible pressure rating of the clamp must be observed.

Pressure transmission medium

Model	Medium
Model UPT-20	Measuring range ≤ 40 bar [500 psi]: Synthetic oil (halocarbon oil for oxygen applications)
	Measuring range > 40 bar [500 psi]: Dry measuring cell
Model UPT-21	Synthetic oil

In general, for oxygen applications, halocarbon oil. The application demands special cleaning processes which ensure oil and grease free surfaces.

Optionally FDA-listed media for the food industry are available.

Diaphragm seals

The model UPT-20 process transmitter can be adapted to the harshest conditions in the process industry by using diaphragm seals. Thus, the transmitter can be used at extreme temperatures, and with aggressive, corrosive, heterogeneous, abrasive, highly viscous or toxic media. As a result of the wide variety of aseptic connections (such as clamp, threaded pipe or DIN 11864 aseptic connections) measuring assemblies meet the high demands of sterile process engineering.



Materials

Wetted parts

Model	Measuring ranges	Process connections	Materials	
UPT-20	≤ 40 bar [500 psi]	All	Standard	Process connection: Stainless steel 1.4404 / 316L Sensor: Stainless steel 1.4404 / 316L
	> 40 bar [500 psi]	All	Standard	Process connection: Stainless steel 1.4404 / 316L Sensor: Elgiloy® 2.4711
	> 1,000 bar [15,000 psi]	All	Standard	Process connection: Stainless steel 1.4534 / XM-13 Sensor: Stainless steel 1.4534 / XM-13
UPT-21	All	All	Standard	Process connection: Stainless steel 1.4435 / 316L Diaphragm: Stainless steel 1.4435 / 316L
		G ½ G 1	Option 1	Process connection: Hastelloy® HC276 / 2.4819 Diaphragm: Hastelloy HC276 / 2.4819
		G ½ G 1	Option 2	Process connection: Gold-plated Diaphragm: Gold-plated ¹⁾

¹⁾ Accuracy 0.1 % not available for gold-plated sensors

All connections are NACE MR0103 and MR0175 compatible. No NACE for measuring ranges > 1,000 bar [15,000 psi] (see page 17)

Elgiloy® is a trademark of the company "Specialty Metals"

Hydrogen applications:

With the measurement of hydrogen, preferably, a gold-plated diaphragm should be used. If this is not technically possible, a higher long-term drift should be expected.

Our technical support is available for questions.

Use with pressures ≥ 1,600 bar is not recommended.

Sealing material

see table under Operating conditions, medium temperature

Non-wetted parts

Case	
Option 1	Plastic (PBT) with conductive surface per EN 60079-0:2012 Colour: Night blue RAL5022
Option 2	Stainless steel case 1.4308 (304 L), precision-cast (suitable for chemical and petrochemical industries)
Option 3	Stainless steel case 1.4308 (304 L) with electropolished surface (suitable for pharmaceutical, food and hygienic industries)
Option 4 ¹⁾	Stainless steel case coated with epoxy resin
Option 5 ¹⁾	Stainless steel case, electropolished and coated with epoxy resin

¹⁾ not suitable for Ex applications

Electrical connections

Connection	Ingress protection	Wire cross-section
Plastic cable gland	IP66/67	max. 2.5 mm ² (AWG 14)
Brass cable gland, nickel-plated	IP66/67	max. 2.5 mm ² (AWG 14)
Stainless steel cable gland	IP66/67	max. 2.5 mm ² (AWG 14)
Stainless steel cable gland in hygienic design	IP66/67	max. 2.5 mm ² (AWG 14)
Angular connector DIN 175301-803A with mating connector	IP65 ¹⁾	max. 1.5 mm ² (AWG 16)
Circular connector M12 x 1 (4-pin) without mating connector	IP65 ¹⁾	-

1) The stated ingress protection only applies when plugged in using mating connectors that have the appropriate ingress protection.

Electrical safety

Reverse polarity protection

Connection diagrams

Cable gland M20 x 1.5 and spring-loaded terminals

Outlet for connection cable

Pin assignment

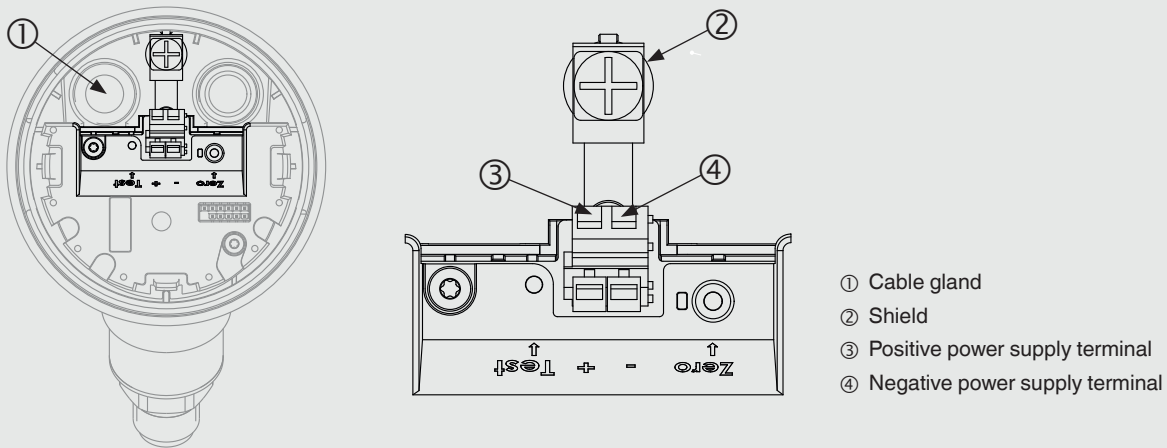

Legend

U₊ Positive power supply terminal

U₋ Negative power supply terminal

Dimensions in mm [in]

Process connections for model UPT-20

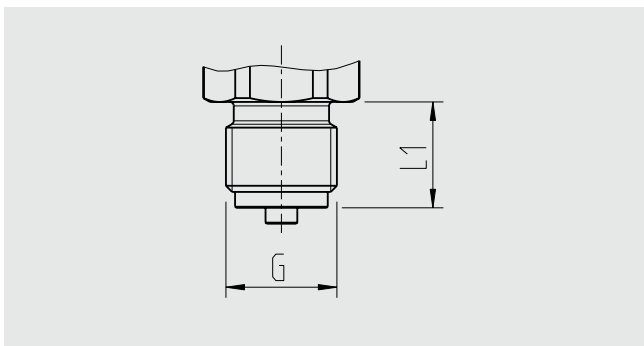

G	L1
G 3/8 B	16 [0.63]
G 1/2 B	20 [0.79]
M20 x 1.5	20 [0.79]

Hexagon dimension: 12 mm [0.47 in]
Spanner width: 27 mm [1.06 in]

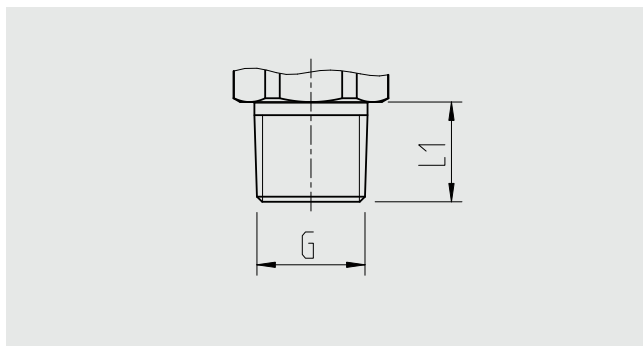

G	L1
1/4 NPT	13 [0.51]
1/2 NPT	19 [0.75]

Hexagon dimension: 12 mm [0.47 in]
Spanner width: 27 mm [1.06 in]

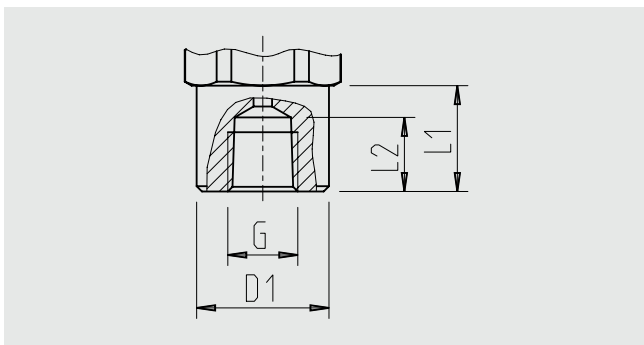

G	L1	L2	D1
Measuring ranges ≤ 40 bar [500 psi]			
1/2 NPT, female	20 [0.79]	19 [0.75]	26.5 [1.04]
Measuring ranges > 40 bar [500 psi]			
1/2 NPT, female	20 [0.79]	19 [0.75]	40.5 [1.59]

Measuring ranges ≤ 40 bar [500 psi]
Hexagon dimension: 10 mm [0.4 in]
Spanner width: 27 mm [1.06 in]

Measuring ranges > 40 bar [500 psi]
Hexagon dimension: 12 mm [0.47 in]
Spanner width: 41 mm [1.61 in]

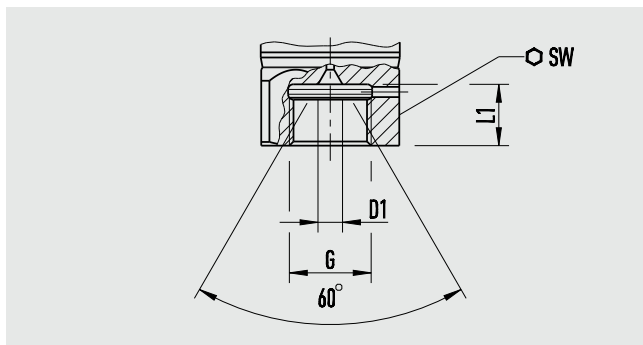

G	L1	D1	SW
M16 x 1.5	12 [0.47]	4.8 [0.19]	27 [1.06]
M20 x 1.5	15 [0.59]	4.8 [0.19]	27 [1.06]

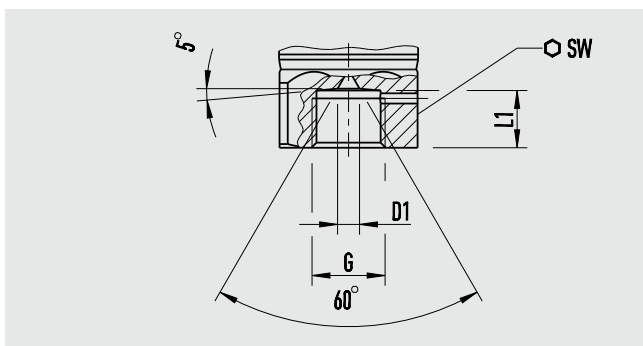

G	L1	D1	SW
9/16-18 UNF female F 250-C	11.2 [0.44]	4.3 [0.17]	27 [1.06]
1 1/8 -12 UNF female F 562-C	19.1 [0.75]	9.7 [0.38]	41 [1.6]

Process connections for model UPT-21

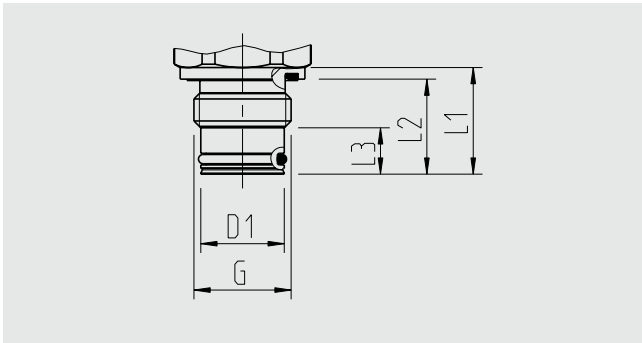

G	L1	L2	L3	D1
G 1/2 B	23 [0.9]	20.5 [0.81]	10 [0.4]	18 [0.71]

Hexagon dimension: 12 mm [0.47 in]
Spanner width: 27 mm [1.06 in]

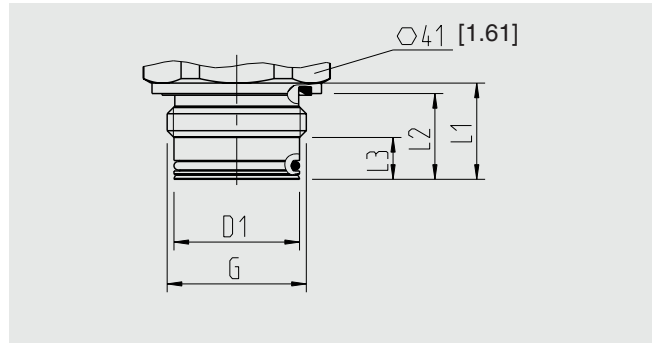

G	L1	L2	L3	D1
G 1 B	23 [0.9]	20.5 [0.81]	10 [0.4]	30 [1.18]

Hexagon dimension: 13 mm [0.51 in]

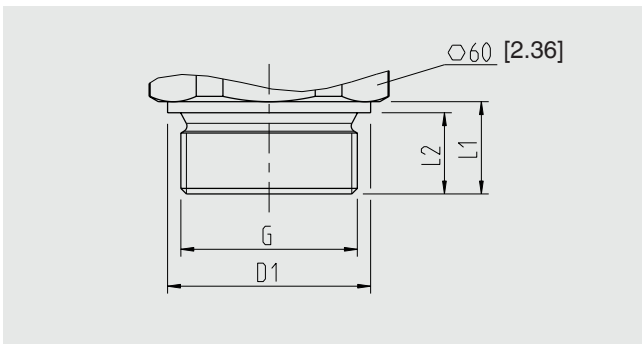

G	L1	L2	D1
G 1 1/2 B	25 [0.99]	22 [0.87]	55 [2.17]

Hygienic

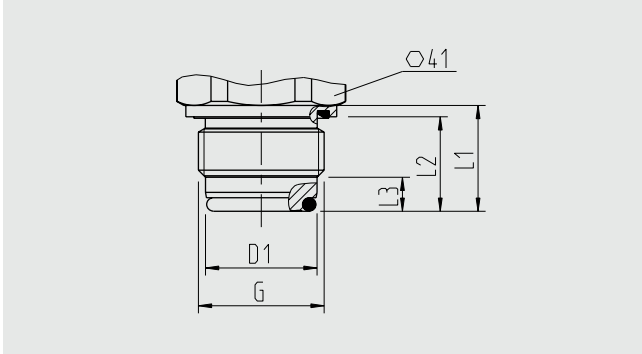

G	L1	L2	L3	D1
G 1 B	28 [1.10]	25 [0.98]	9 [0.35]	29.5 [1.16]

Hygienic

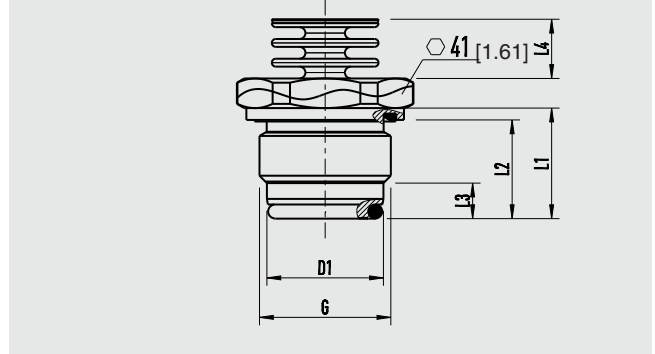

G	L1	L2	L3	L4	D1
G 1 B	28 [1.10]	25 [0.98]	9 [0.35]	15.5 [0.61]	29.5 [1.16]

Hygienic connections for food industry, pharmaceutical industry and sanitary applications

Clamp connection (clamp)

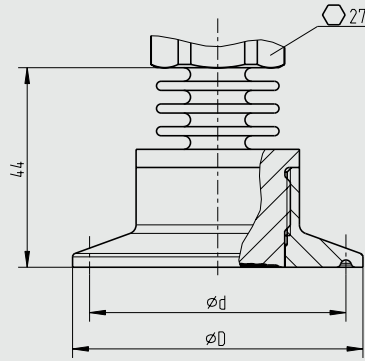

		ØD	Ød
DIN 32676 Tri-clamp ¹⁾	DN 1 ½	50,5 [1.99]	43,5 [1.71]
	DN 2	64 [2.52]	56,6 [2.23]
	DN 40	50,5 [1.99]	43,5 [1.71]
	DN 50	64 [2.52]	56,6 [2.23]

Hexagon height: 12.5 mm [0.49 in]
 1) Process connections per ASME BPE

Grooved union nut DIN 11851 with conical coupling, for pipes per DIN 11850

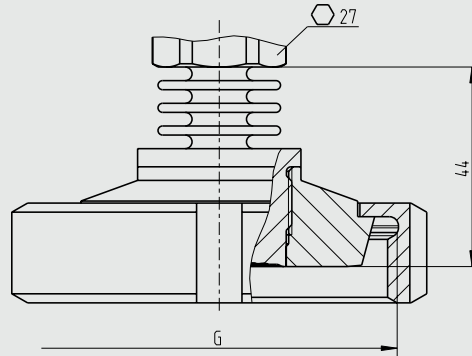

		G	Ød ₃
DIN 11851	DN 25	Rd 52 x 1/6	44 [1.73]
	DN 50	Rd 78 x 1/6	61 [2.40]

Hexagon height: 12.5 mm [0.49 in]

For a 3-A conform connection of process connections with milk thread fittings per DIN 11851, profile sealings from SKS Komponenten BV or Kieselmann GmbH have to be used.

VARIVENT®

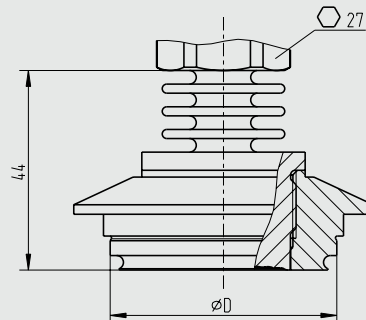

		ØD
VARIVENT®	Form F	50 [1.97]
	Form N	68 [2.68]

Hexagon height: 12.5 mm [0.49 in]

NEUMO BioConnect®
Flange, V shape

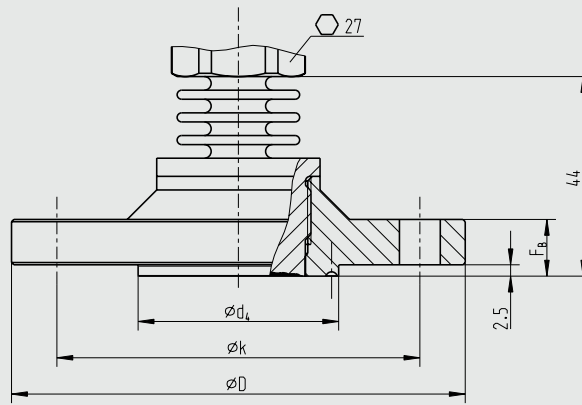

		$\varnothing d_2$	$\varnothing d_4$	$\varnothing D$	$\varnothing k$	F_B
BioConnect®	DN 40	4 x 9 [0.16 x 0.35]	44.2 [1.74]	100 [3.94]	80 [3.15]	10 [0.39]

Hexagon height: 12.5 mm [0.49 in]

DRD retainer flange

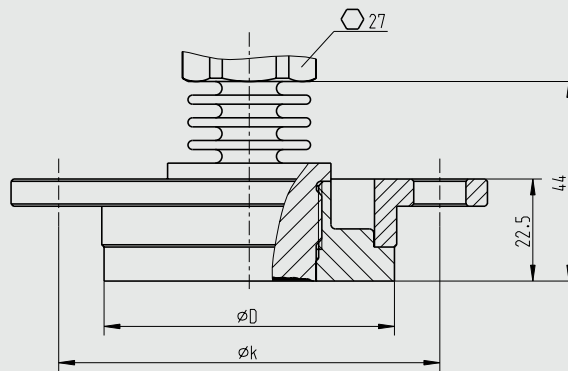

		$\varnothing D$	$\varnothing k$
DRD retainer flange	PN 40	64 [2.52]	84 [3.31]

Hexagon height: 12.5 mm [0.49 in]

Electropolished wetted surfaces for sanitary applications:

- Unpolished surface $R_a \leq 0.5 \mu\text{m}$
- Polished surface $R_a \leq 0.38 \mu\text{m}$

Process transmitter with plastic case, models UPT-20 and UPT-21

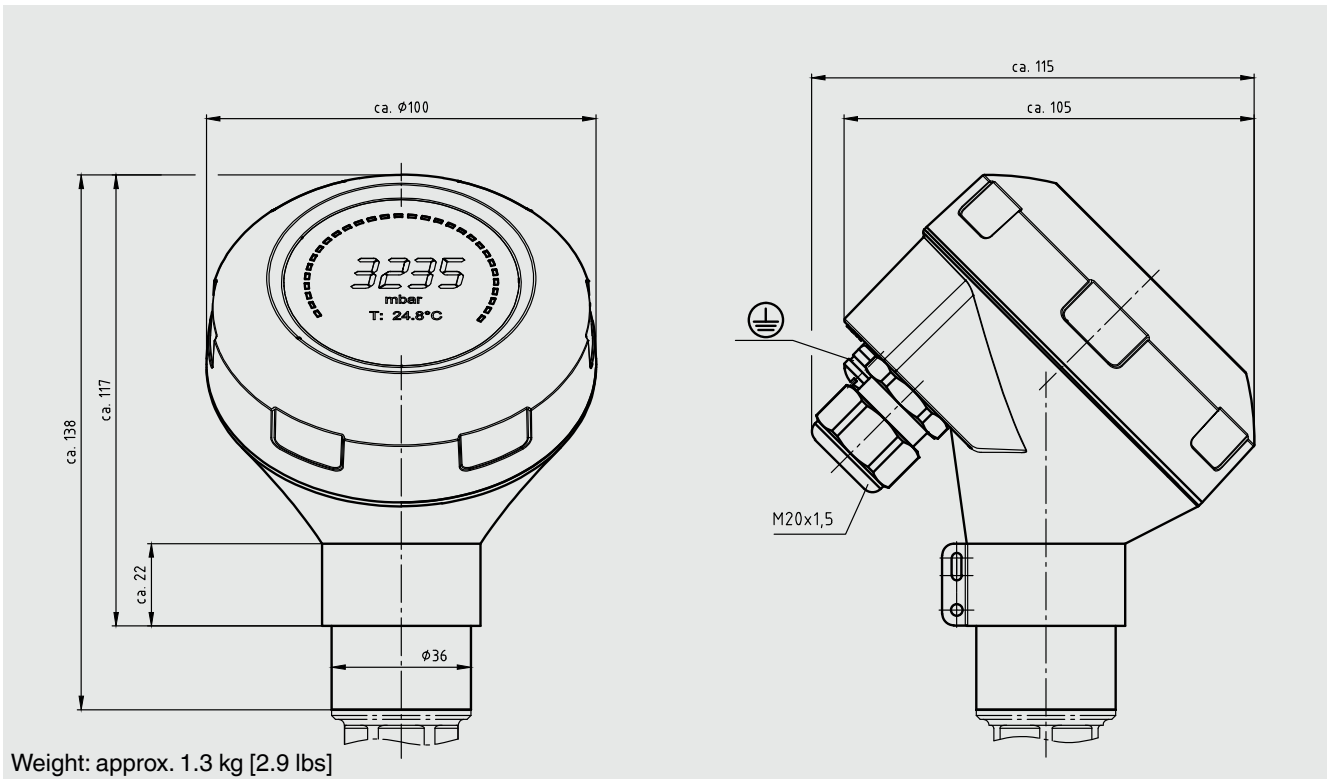



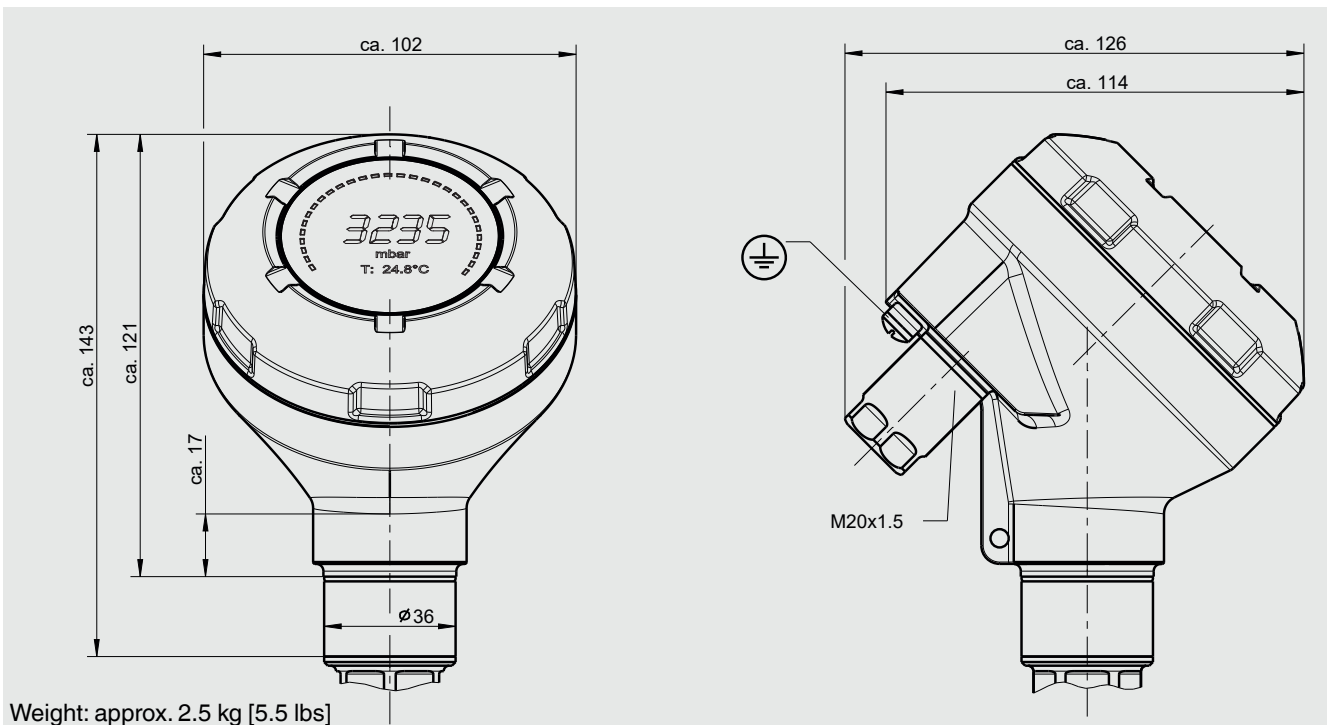





Process transmitter with stainless steel case and hygienic M20 x 1.5 cable gland, models UPT-20 and UPT-21





Accessories

	Description	Order no.
	<p>Display module, model DIH52-F 5-digit display, 20-segment bar graph, without separate power supply, with additional HART® functionality. Automatic adjustment of measuring range and span. Secondary-master functionality: Setting the measuring range and unit of the connected transmitter using HART® standard commands possible. Optional: Explosion protection per ATEX</p>	on request
	<p>HART® modem USB interface, model 010031 RS-232 interface, model 010001 Bluetooth® interface [EEx ia] IIC, model 010041</p>	11025166 7957522 11364254
	<p>HART® modem, PowerXpress USB interface 2.0 Voltage supply via USB or AC 100/250 V, 50/60 Hz power supply unit Requires Windows 98, 2000, XP (32-bit), VISTA (32-bit), Windows 7 (32/64-bit)</p>	14133234
	<p>Welding socket for process connection G ½ flush for process connection G 1 flush for process connection G 1 ½ flush for process connection G 1 hygienic flush</p>	1192299 1192264 2158982 14070973
	<p>Instrument mounting bracket for wall or pipe mounting, stainless steel Weight: approx. 0.4 kg [0.9 lbs]</p>	14058660
	<p>Overvoltage protection for transmitters, 4 ... 20 mA, M20 x 1.5, series connection</p>	14002489
	<p>Display and operating unit, model DI-PT-U The display and operating unit can be attached in 90° steps. The display and operating unit features a main display and an additional display. The main display shows the output signal. The additional display shows different values, at the same time as the main display - these values can be selected by the user. The process pressure transmitter can be configured through the display and operating unit. Only this display may be used for installation into the process transmitter.</p>	14090181
	<p>Block-and-bleed valve, models IV20 and IV21 See data sheet AC 09.19</p>	
	<p>Hygienic cable gland M20 x 1.5</p>	11348691

Approvals (option)

Logo	Description	Country
	EU declaration of conformity <ul style="list-style-type: none"> ■ EMC directive, interference emission (group 1, class B) and immunity per EN 61326-1:2013 (industrial application), EN 61326-2-3:2013 ¹⁾ ■ Pressure equipment directive ■ RoHS directive ■ ATEX directive <ul style="list-style-type: none"> - Ex i Zone 1 gas [II 2G Ex ia IIC T4/T5/T6 Gb] Zone 1 mounting to zone 0 gas [II 1/2G Ex ia IIC T4/T5/T6 Ga/Gb] Zone 2 gas [II 3G Ex ic IIC T4/T5/T6 Gc] Zone 21 dust [II 2D Ex ia IIIC T135 °C Db] Zone 21 mounting to zone 20 dust [II 1/2D Ex ia IIIC T135 °C Da/Db] 	European Union
	IECEx Hazardous areas <ul style="list-style-type: none"> - Ex i Zone 1 gas [Ex ia IIC T6 ... T3 Gb] Zone 1 mounting to zone 0 gas [Ex ia IIC T6 ... T3 Ga/Gb] Zone 2 gas [Ex ia IIC T6 ... T3 Gc] Zone 21 dust [Ex ia IIIC T135 °C Db] Zone 21 mounting to zone 20 dust [Ex ia IIIC T135 °C Da/Db] 	International
	EAC <ul style="list-style-type: none"> ■ Pressure equipment directive ■ Electromagnetic compatibility ■ Hazardous areas <ul style="list-style-type: none"> - Ex i Zone 0 gas [0ExiaIIC T4/T5/T6 X] Zone 1 gas [1ExiaIIC T4/T5/T6 X] Zone 2 gas [2ExiaIIC T4/T5/T6 X] Zone 21 dust [Ex iaD 20 T135 °C X] Zone 20 dust [Ex iaD 21 T135 °C X] 	Eurasian Economic Community
	GOST Metrology, measurement technology	Russia
	KazInMetr Metrology, measurement technology	Kazakhstan
	MTSCHS Permission for commissioning	Kazakhstan
	UkrSEPRO Metrology, measurement technology	Ukraine
	DNOP_MakNII <ul style="list-style-type: none"> ■ Mining ■ Hazardous areas <ul style="list-style-type: none"> - Ex i Zone 1 mounting to zone 0 gas [II 1/2G EEx ia IIC T4/T5/T6 Ga/Gb] Zone 21 mounting to zone 20 dust [II 1/2D IP6X T130 °C/T95 °C/T80 °C] 	Ukraine
	Uzstandard Metrology, measurement technology	Uzbekistan
	INMETRO <ul style="list-style-type: none"> ■ Metrology, measurement technology ■ Hazardous areas <ul style="list-style-type: none"> - Ex i Zone 1 gas [Ex ia IIC T6 ... T3 Gb] Zone 1 mounting to zone 0 gas [Ex ia IIC T6 ... T3 Ga/Gb] Zone 2 gas [Ex ia IIC T6 ... T3 Gc] Zone 21 dust [Ex ia IIIC T135 °C Db] Zone 21 mounting to zone 20 dust [Ex ia IIIC T135 °C Da/Db] 	Brazil

Logo	Description	Country
	KCs (KOSHA) Hazardous areas - Ex i Zone 1 to zone 0 [Ex ia IIC T3 ... T6] Zone 1 [Ex ia IIC T3 ... T6] Zone 21 to zone 20 [Ex iD A21 135 °C] Zone 21 [Ex iD A21 135 °C] - Ex n Zone 2 [Ex nL IIC T3 ... T6]	South Korea
	3-A Food This instrument is 3-A marked, based on a third party verification for conformance to the 3-A standard.	International
	EHEDG Hygienic Equipment Design	

1) With electrostatic discharge, a short-term, increased error of up to 1 % of the nominal measuring range can occur.

Manufacturer's information and certificates

NAMUR recommendations

NAMUR is the automation technology interest group for the process industry in Germany. The published NAMUR recommendations are considered standards in field instrumentation, and also have the character of international standards.

The instrument fulfils the requirements of the following NAMUR recommendations:

- NE21 - Electromagnetic compatibility of equipment
- NE43 - Signal level for failure information for transmitters
- NE53 - Compatibility of field instruments and display and operating components
- NE107 - Self-monitoring and diagnostics of field instruments

For further information, see www.namur.net/en

NACE

NACE is a term for an organisation (National Association of Corrosion Engineers) concerned with the topic of corrosion. The results of this organisation are published as NACE standards and regularly updated.

The instruments and, in particular, the weld seams fulfil:

- NACE MR0103 - Applications in oil refineries
- NACE MR0175 - Oil extraction and processing

FDA conform filling and sealing

The FDA is the American supervisory authority for the area of "food and drugs", which also controls all goods placed on the market. An important topic is the use of substances that can come into contact with foodstuffs. Stainless steels are generally not critical, but plastics (such as sealings) and liquids (e.g. pressure transmission media for use in food, pharmaceutical and biotechnology applications) must be designed in accordance with the requirements of the FDA.

Some of the substances in these instruments are classified as FDA conform.

Certificates (option)

- Test certificate for the measurement accuracy is in the scope of delivery (5 measuring points in the scaled range)
- 2.2 test report
- 3.1 inspection certificate
- DKD/DAkkS calibration per IEC 17025

Approvals and certificates, see website

Ordering information

Model / Explosion protection / Case version / Digital display / Output signal / Electrical connection / Measuring range / Process connection / Sealing / Wetted parts / Accuracy / Certificates / Scaling

© 04/2014 WIKA Alexander Wiegand SE & Co. KG, all rights reserved.
The specifications given in this document represent the state of engineering at the time of publishing.
We reserve the right to make modifications to the specifications and materials.

