

# BILL OF MATERIAL

ITEM	PART NAME	MATERIALS
1	BODY	SA-479, 316 SS
2	BONNET	SA-479, 316 SS
3	CAP	TYPE 316 SS
4	SPRING ADJUSTING SCREW	TYPE 316 SS
5	SPRING BUTTON	TYPE 316 SS
6	SPRING	INCONEL X750
7	SPRING BUTTON	TYPE 316 SS
8	DISC	TYPE 316 SS
9	JAM NUT	18-8 SS
10	GUIDE	TYPE 316 SS
11	GUIDE FLANGE	TYPE 316 SS
12	UPPER SEAT SEAL	VITON
13	UPPER SEAT	TYPE 316 SS
14	STATIC SEAL, BODY	VITON
15	BLOWDOWN RELAY	TYPE 316 SS
16	LOWER SEAT	TYPE 316 SS
17	RETAINER, LOWER SEAT	TYPE 316 SS
18	LOWER SEAT SEAL	VITON
19	STATIC SEAL, ADJUSTER	VITON
20	BLOWDOWN ADJUSTER	A479 316 SS
21	STATIC SEAL, FILTER	VITON
22	FILTER	SERIES 300 SS
23	FILTER HOUSING	TYPE 316 SS
24	POPPET	TYPE 316 SS
25	ADJUSTER CAP SEAL	VITON
26	BLOWDOWN ADJUSTER CAP	TYPE 316 SS
27	THREAD SEAL	TEFLON
28	BLOWDOWN ADJ. LOCKNUT	18-8 SS
29	BUG VENT	COMMERCIAL GRADE
30	WIRE SEAL	SS WIRE / LEAD SEAL
31	NAMEPLATE (NOT SHOWN)	SS

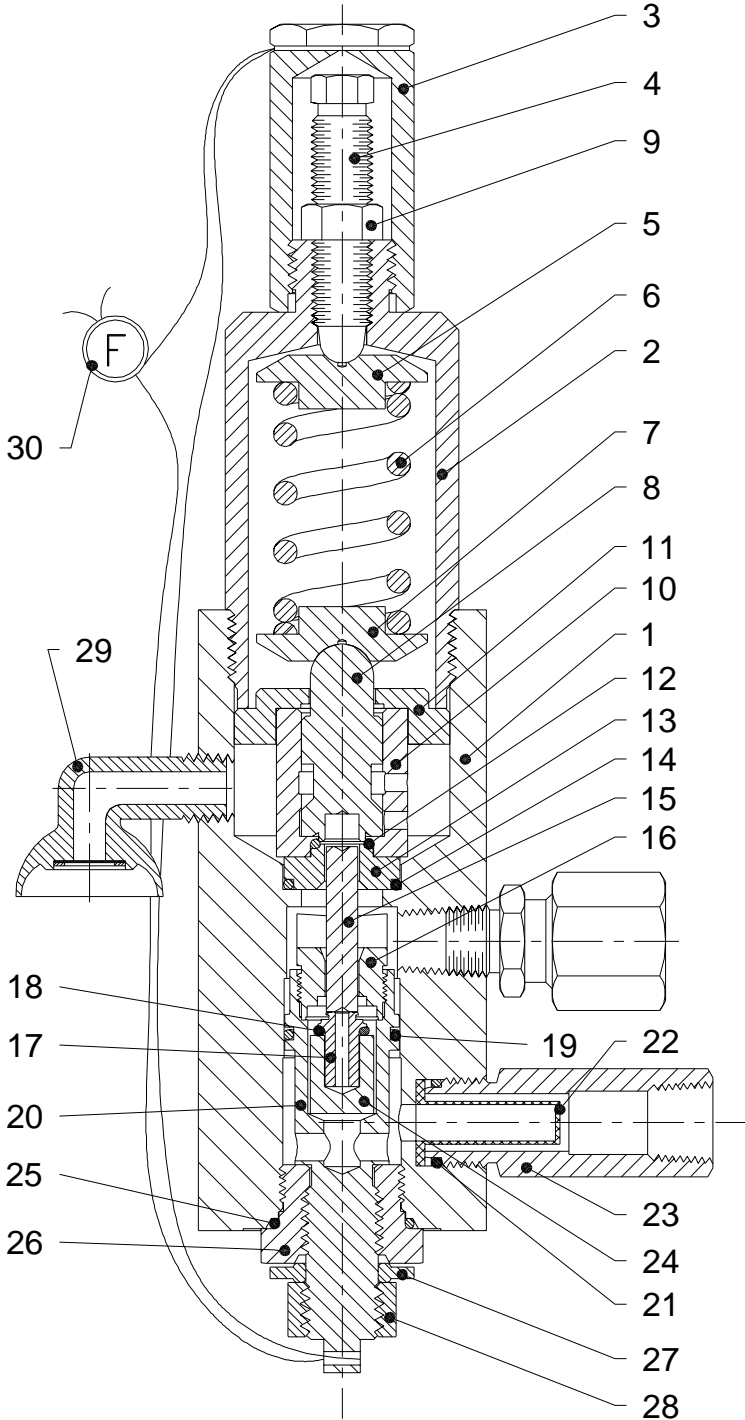

### General Notes:

### TAG NUMBERS & SPECIFICATIONS

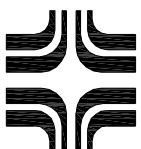

**FARRIS ENGINEERING**  
 Division of Curtiss-Wright Flow Control Corporation  
 TITLE: PCF5  
 DRAWING NUMBER: 27879X1-F

CUSTOMER: -  
 P.O.#: -  
 F.O.#: -  
 DATE: 20 JUNE 05

ORIFICE

API ASME

-

-